

VAE
CONTROLS

ISO 9001
ISO 10006
ISO 14001
ISO 21500
ISO 27001
OHSAS 45001
NATO CONFIDENTIAL
SCC

KEY FEATURES

- Highly vibration resistant
- 28 various tones available
- Selectable sound level
- Stainless steel body
- Wide operating input voltage range
- High Ingress Protection
- Suitable also for mines



ATEX certified
Zone 1 and 2

I M2 Ex ib d I Mb
II 2G Ex ib d IIB T4 Gb

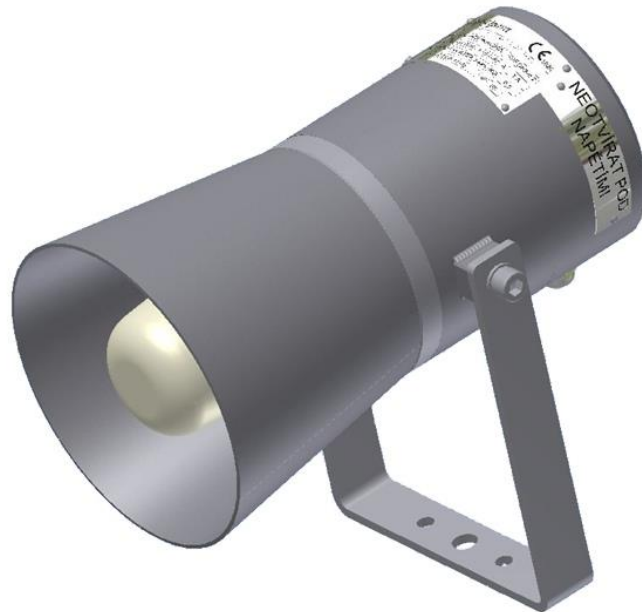

SOUNDER DB3 is designed for industrial applications in explosive hazardous areas. There are 2 options – one for underground mines and one for explosive hazardous areas zone 1 and 2. The equipment is designed as a compact unit with holder and possibility to set the angle.

APPLICATIONS

- Underground parts of mines
- Overground parts of mines
- Chemical plants
- Refineries
- Fuels and oil products storages and terminals
- Pipeline pumping and compressor stations
- Gas storage facilities

VAE CONTROLS GROUP

SOUNDER DB3

for sound alarms in explosive hazardous areas

SPECIFICATIONS

Model	DB3-d.2	DB3-d.3
Protection	ATEX I M2 Ex ib d I Mb	ATEX II 2G Ex ib d IIB T4 Gb
Ingress Protection	IP65	
Ambient Temperature	-20 °C to +40 °C	
Storage Temperature	0 °C to +40 °C	
Power supply voltage	12 - 48 VDC	
Power Consumption		
@ 12 VDC	≤ 8 W	≤ 2.9 W
@ 24 VDC	≤ 9 W	≤ 3.3 W
@ 48 VDC	≤ 10 W	≤ 3.7 W
Cable Gland	M16x1.5 Exd	
Cable Type	2-core, 0.75 - 1.5 mm ² , Ø 4 - 8 mm	
Cable Length	> 3 m	
Grounding	Grounded via fixing bracket	
Dimensions	Ø 190 x 285 mm	
Weight	9.5 kg	
Case	Stainless steel	
Installation	Flat surface, 2 x bolt M8	
Mounting position	Recommended horizontal	
Sound intensity @ 1 m	0 - 115 dB	0 - 100 dB
Volume levels	4 pre-defined	
Number of tones	28 pre-defined	

Side view

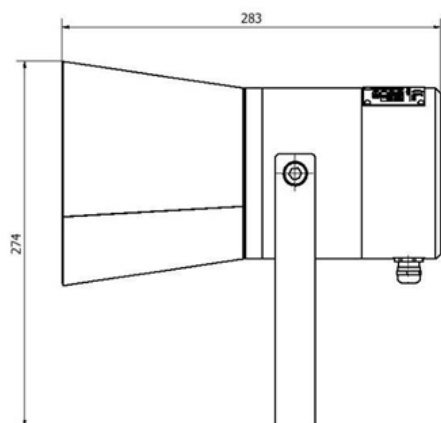

Front view

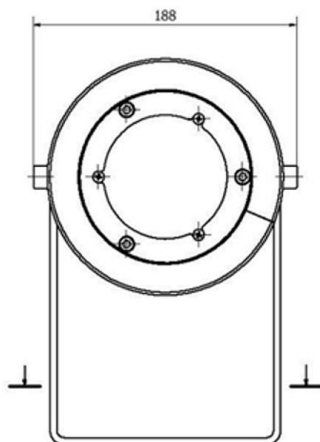

Base view

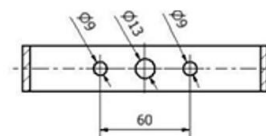

PROFESSIONAL SOLUTIONS FOR OIL&GAS AND WATER INDUSTRY